

**Specification**

Model	Unit	PT-051/052	PT-103/104	PT-203/204
Power input		1Ø 100~240VAC 50/60Hz		
Capacity (Horizontal / Vertical)	kg	50 / 30	100 / 60	200 / 130
Rated eccentricity	mm	30	A:180 B:90 C:60 D:45	A:84 B:42 C:28 D:10
Table dimension	mm	Ø200	Ø320	
Rotation speed	rpm	0.5 ~ 8	A:0.3~4 B:0.6~8 C:0.8~12 D:1~16	
Through hole diameter	mm	Ø14	Ø22	
Earthing	amp	300	300	
Tilt range	deg	0 ~ 90	0 ~ 120	
Dimension (A x B x C)	mm	320 x 240 x 265	460 x 315 x 340	
Center to floor (D)	mm	205	250	
Weight	kg	10	38	42

※ Specification is subject to change without prior notice.

**Dimensions**

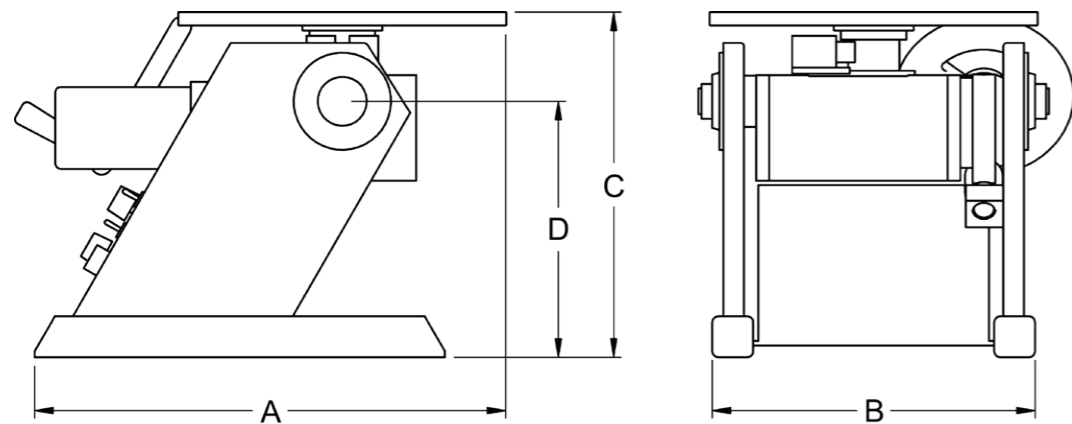

• U Type

• PT-204

ProArc offers the latest generation E.Z.Arc circumferential welding system, providing the broadest selection of components to help customers create their automatic welding systems more easily and achieve the highest quality welding results.

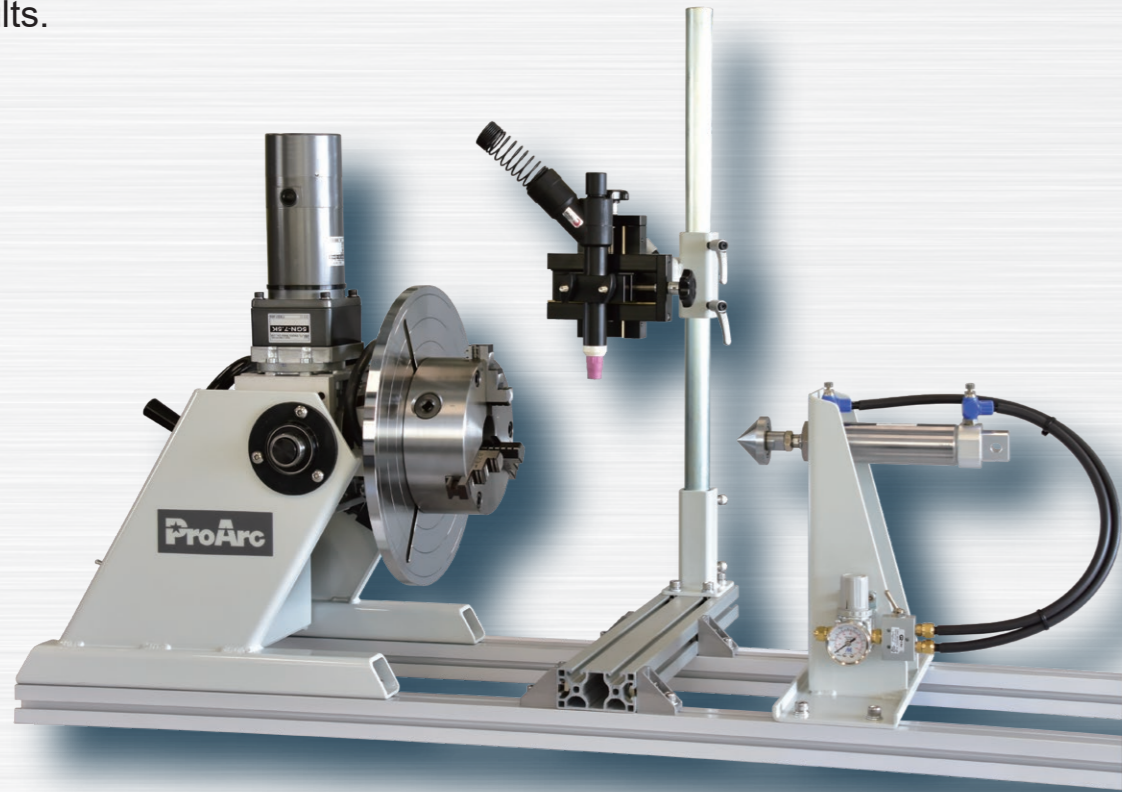

• L Type

**Features**

- Modern style and more compact design
- Advanced design PCB for new control box
- High frequency protected
- Standard / digital type in 4 rotation speed available
- CE Conformity

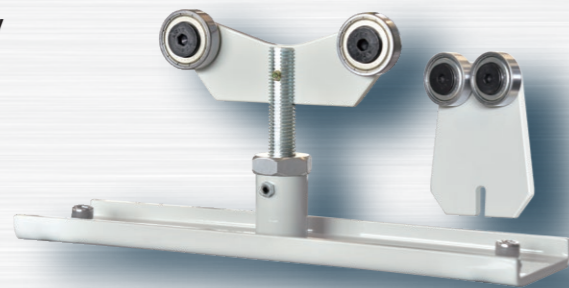

• IS-300

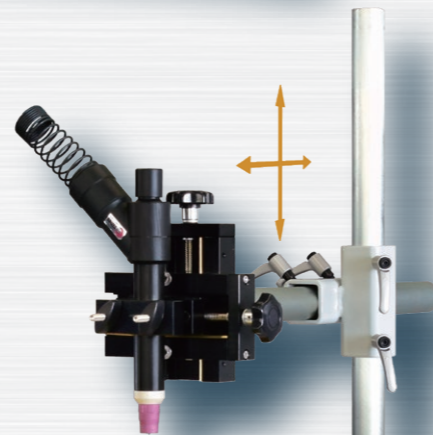

• TH-650

※ Easily attaches to a welding table



• PT-103



• PT-051

**Options**

Model	Description	Part No.
TH-650	Torch holder	6236-5000
IS-300	Idler stand, Ø70 ~ 300mm	6230-3001
TG-300	Tungsten Grinder, Ø1.0 ~ 4.8mm	
WO-15	Weaving oscillator	6405-1510
CB-101	Standard control	6501-0110
CB-101D	Digital standard control	6501-0120
CB-102	Sequencer, original sensor control	6511-0210
CB-102D	Digital sequencer, original sensor control	6511-0220
CB-107	Smart controller, fully automated control	6511-0720
TA-101	Pneumatic torch actuator, 100mm stroke	6231-0110
TL-101	Pneumatic torch lift, tilt angle 30°	6231-0121
SV-260	Safety viewer, W:260mm	6235-0010
PG-150	3-Jaw chuck, OD 4 ~ 150mm	6401-0050
PG-300	3-Jaw chuck, OD 4 ~ 300mm	6401-0300
VSFC-1K	Variable speed foot control	6502-0011

• TG-300



• WO-15



• CB-107



• PG-300



• SV-260



• TL-101

